

Transport Problems

Volume 18 Issue 4



Problemy Transportu



GLIWICE 2023

SCIENTIFIC
JOURNAL

TRANSPORT PROBLEMS
Volume 18 Issue 4

PROBLEMY TRANSPORTU
Tom 18 Zeszyt 4

QUARTERLY

WYDAWNICTWO POLITECHNIKI ŚLĄSKIEJ
GLIWICE 2023

CONTENTS

	Page
1. Ali M., Macioszek E.: The influence of travel mode choice on subjective well-being - a case study	5
2. Vida L., Illés B., Véha A.: A modal shift, but how?	19
3. Adenigbo A.J., Mageto J., Luke R.: Factors influencing air cargo policy decisions and implementation in Nigeria: a stakeholder's perspective	33
4. Adrie F.M., Rakhmatulloh A.R., Dewi D.I.K.: Preferences for bicycling and connecting to bus rapid transit in Yogyakarta, Indonesia	47
5. Sendek-Matysiak E., Lewicki W., Łosiewicz Z., Homik W.: Assessment of knowledge of young users and their views on e-mobility	59
6. Bizoń K., Chmielewska A., Chudzikiewicz A., Śładkowski A., Stelmach A.: Integrated research of multi-purpose stanchion baskets for transporting timber and containers	73
7. Bęczkowska S., Grabarek I., Kozłowski M.: Identification of inconveniences at transport operators' workplaces	87
8. Woodburn J., Bielaczyc P., Merkisz J., Pielecha J.: Laboratory and on-road characterization of exhaust emissions from plug-in hybrid vehicles at multiple battery states of charge conditions	99
9. Dyczkowska J., Olkiewicz M.: Bicycle infrastructure: an element of sustainable mobility in the West Pomeranian Voivodeship	113
10. Pečman J., Stopka O., Rybicka I., Stopková M.: Influence of road longitudinal terrain profile on vehicle kinetic energy recovery and mitigation of selected transport negative aspects	125
11. Shalapko D.: Optical-graphic studies of hydrogen additives' effects on diesel fuel atomization parameters	135
12. Gogiashvili P., Kirtadze S., Lekveishvili G., Kbilashvili D., Chogovadze J., Sirbiladze B.: Improving the efficiency of transporting lightweight bulky cargo by motor transport	147
13. Homik W., Mazurkow A., Chmielowiec A.: Determination of a torsional vibration viscous damper's operating temperature using a new thermohydrodynamic model	161
14. Fava L.C., Fugihara M.K., Sampaio M.: Supply chain design: a case study in a pulp and paper company	175
15. Asmael N.M., Waheed M.Q.: Analysis of pedestrian characteristics crossing along roads	189
16. Sternad M., Grofelnik I.: Comparison of railway performance in the European Union based on DEA analysis during COVID crisis	201
17. Passoli A., Dizewe K., Aholou C.: Intermodality between artisanal transport and public transport by bus in Grand Lome	211
18. Żmuda W., Czubak P.: Operation of a new single-vibrator conveyor on the falling slope of the second resonance	223
List of reviewers	233

Keywords: multi-purpose stanchion basket; transporting timber and containers; innovative design solution

Krzysztof BIZOŃ¹, Aleksandra CHMIELEWSKA², Andrzej CHUDZIKIEWICZ^{3*},
Aleksander ŚLADKOWSKI⁴, Anna STELMACH⁵

INTEGRATED RESEARCH OF MULTI-PURPOSE STANCHION BASKETS FOR TRANSPORTING TIMBER AND CONTAINERS

Summary. Analyses of cargo transport in 2021 show that despite the increased volume of cargo transported by all types of transport compared to 2020, road transport is still dominant compared to rail transport. Therefore, all actions aimed at improving these unfavorable relations (rail transport vs. road transport) in transport, particularly cargo transport, should be considered purposeful and justified. One such activity is the ongoing work on the design and construction of freight wagons for specialized transport. Unlike universal wagons, specialized wagons are characterized by a limited ability to transport a wide range of material groups. An example is the transport of timber. However, the development of new transport technologies, and above all, technical and organizational progress, force the organizers of these transport modes to look for new logistic and rolling stock solutions. The aforementioned transport of timber is an example of this. The transport of wood does not constitute a large volume of transport, but taking into account its transport issues (transport with large truck tractors, high axle loads, and high risks for other road users), it is a classic example of the fact that it should not be carried out by road over long distances. Therefore, all actions aimed at reducing these issues and improving efficiency by using rail transport are desirable and even necessary. The article presents an innovative design solution in the form of a stanchion basket installed on flat wagons, allowing the use of standard wagons of this type to transport both containers and timber as well as loads such as beams and pipes. Such a solution will allow the use of empty runs of these wagons after unloading wood at the destination station for further transport of containers and vice versa. The considerations described in the article show the research process at the construction stage and testing the prototype of the built basket and the wagon with the stanchion basket structure placed on it.

1. INTRODUCTION

In 2021, 2,253.4 million tonnes of freight were transported by all modes (2.4% more than before 2021), and freight work of 491.4 billion tonne-kilometers will be performed (3.6% more than in the previous year) [1]. There was an increase in freight transport in almost every mode, with the exception

¹ Silesian University of Technology, Faculty of Transport and Aviation Engineering; Krasińskiego 8, 40-019 Katowice, Poland; e-mail: Krzysztof.Bizon@polsl.pl; orcid.org/0000-0002-1575-2016

² University of Warsaw, Faculty of Journalism, Information and Book Studies; Bednarska 2/4, 00-310 Warsaw; e-mail: a.chmielewska11@uw.edu.pl; orcid.org/0000-0002-5701-8098

³ Kazimierz Pułaski University in Radom, Faculty of Transport, Electrical Engineering and Computer Science, Malczewskiego 29, 26-600 Radom; e-mail: chudzikiewicz.andrzej@gmail.com; orcid.org/0000-0003-4767-4056

⁴ Silesian University of Technology, Faculty of Transport and Aviation Engineering; Krasińskiego 8, 40-019 Katowice, Poland; e-mail: Krzysztof.Bizon@polsl.pl; orcid.org/0000-0002-1041-4309

⁵ Warsaw University of Technology, Faculty of Transport; Koszykowa 75, 00-662 Warsaw, Poland; e-mail: anna.stelmach@pw.edu.pl; orcid.org/0000-0002-2301-6908

* Corresponding author. E-mail: chudzikiewicz.andrzej@gmail.com

of pipeline transport. Although rail transport carried 8.9% more freight in the period under review than in 2020, this is still only almost 11% of the total tonnage carried. Obviously, the dominant role in this transport is still played by road transport, which carries 86.6% of all freight. Therefore, all actions aimed at improving this unfavorable relationship (rail vs. road) in transport and especially in freight should be considered purposeful and justified. One such activity is the ongoing work in the field of construction and design of freight wagons for specialized transport [2, 17-19]. Ongoing research concerns not only new body designs but also susceptible systems, which is important considering the loads on sets and bogies when transporting unusual materials [20-22]. In the case of specialized wagons, which belong to the group of atypical wagons, research has been carried out using simulation analysis methods to assess the behavior of such a wagon in the case of tracks with different states of maintenance and geometry [23, 24]. Analyses and numerical studies carried out at the construction stage have been performed using specialized packages such as Matlab, Medina, and Adams [25-27]. Specialized wagons, unlike universal wagons, are characterized by their limited ability to transport a wide range of material groups. An example is the carriage of timber. The design of such wagons is sophisticated considering the equipment and instrumentation involved, as well as their adaptation to the carriage of specific loads and user requirements. However, the development of new haulage technologies and, above all, technical and organizational advances are forcing the organizers of these transport modes to act in search of new solutions, both logistical and rolling stock [3]. The transport of timber mentioned earlier is an example of this [4]. The transport of timber (sixth freight group in rail transport), considering domestic and international transport work, is only 0.1 billion ton-km in domestic and 0.5 billion ton-km in international transport [5]. This does not constitute a quantitatively large transport volume but considering its transport inconvenience (transport with large truck tractors, high axle loads, and serious danger for other road users), it is a classic example that it should not be transported by road over longer distances. Therefore, any action to reduce its inconvenience and improve its efficiency using rail transport is desirable and even necessary [28-31].

This paper presents an innovative design solution in the form of a stanchion basket, allowing the use of standard timber wagons and the transport of containers, which would allow the use of empty runs of these wagons after the timber has been unloaded at the destination station.

2. TIMBER AND CONTAINER MARKET

There are 7,500 companies operating in the Polish wood market, which generate 11% of the revenue in industrial processing (i.e., almost PLN 30 billion) annually. The sector includes furniture companies, wood panel manufacturers, pulp and paper combiners, and producers of sawn timber, pallets, wooden floors, and wooden houses. Poland is the EU's largest producer of wooden floors, HDF (High Density Fibreboard) / MDF (Medium Density Fibreboard) boards, and garden equipment; the fourth-largest furniture producer; the second-largest particle board producer; and the eighth-largest sawn timber producer. It is also the third-largest exporter of furniture in the world and the largest exporter of joinery in Europe [6, CSO]. With such developed production, the demand for wood among producers scattered all over the country is significant and cannot be met by road transport alone. As many as 95% of the 7,500 companies in this industry are small and very small units, processing up to 10,000 m³ of roundwood/year. Companies processing from 100,000 m³ in a year to several million m³ of timber constitute only 0.48% of all companies, of which only eight entities buy more than 500,000 m³ of timber. The raw material these companies purchased, representing a potential cargo for domestic rail transport, is 14.6 million m³, i.e., about 10.95 million tonnes [7].

Because of the decrease in the supply of wood in the domestic market and the increasing difficulty in its acquisition due to the changing legislative conditions, the significance of imported wood and, thus, the significance of rail transport in these transports is increasing [8]. It is estimated that the deficit of wood raw material in Poland is about 4 million m³. More than 1.5 million m³ of raw material is exported, and the same amount is imported [6], which indicates a demand for the transport of 7 million m³ of wood (about 5.25 million tonnes) per year in international traffic. The demand for wood will increase due to environmental issues, most notably the negative impact of plastic on the environment and the

trend towards replacing it with natural raw materials. These figures show that all measures for a better, more efficient use of rail transport for timber are desirable and necessary. One possibility is to eliminate empty runs of wagons transporting timber to companies that process this raw material after unloading and use them to transport the final products of these companies. The problem, however, is the specific design of these specialized wagons, which does not allow direct loading, for example, of pallets or crates of finished products. The present study proposes a structural solution in the form of a special basket directly placed on the platform of a specialized timber wagon, enabling the transport of containers in accordance with current railway regulations.

Containers are the main loading units in intermodal transport, which is one of the most dynamically developing supply areas in Poland. In 2020, intermodal transport in Poland carried 23.8 million tonnes of cargo, an increase of 22% year-on-year. Significantly, the growth dynamics are sustainable. Over the last decade, the weight of freight transported has been continuously increasing, reaching an increase, compared to 2010, of over 440% in 2020 [9].

Containers accounted for more than 95% of the carriage. The largest number of 20- and 40-foot containers were carried, accounting for 37.3% and 53.2% of the total number of units, respectively. Semi-trailers and car trailers in intermodal transport account for 2.4% of the units used, and swap bodies represent only 1%.

The structure of the rolling stock is influenced by the increasing share of private carriers. Currently, Polish rail carriers have 3,650 electric and diesel locomotives and over 91,100 wagons (covered, coal, platform, tank, and special wagons) at their disposal. Compared to 2018, the number of locomotives on the Polish market has increased, while the number of wagons has decreased. The average age of wagons is 30 years, and the average age of locomotives is 36 years. The commercial speed of intermodal trains is 31.69 km/h.

Despite the significant growth of container transport in Poland, intermodal transport by rail accounts for only 10% of freight transport, while it is 29% in Germany and 23% in the EU on average.

3. TIMBER ROLLING STOCK

There have been a number of developments in the rail freight market in recent years, particularly in the context of the growing share of private operators. This affects the structure of the rolling stock used for freight. The services offered by companies leasing or holding rolling stock are increasingly being used by licensed private haulers, but there are also haulers operating in the timber market who are aiming to have their own specialized rolling stock. In this case, it is important that the rolling stock is multifunctional (i.e., able to carry not only timber but also other cargo units, such as containers). The structure of the traction vehicles and wagons of Polish freight operators in 2011-2019 is shown in Table 1 [10]. Timber can be transported by freight wagons of the following types: boxcars, platform wagons, and covered wagons, but in a very limited freight assortment. On the other hand, platform wagons (though not of every type) and special wagons, which cannot be used directly for the carriage of logs, can be used for the carriage of containers.

The most numerous group of freight wagons are platform wagons, which are designed to carry concentrated loads, logs, vehicles, and piece goods. Platform wagons are distinguished by their construction and number of axles. Platform wagons of normal construction on the axles and bogies may be fitted with sideboards and stanchions to immobilize the goods resting on the wagon. Some of these wagons also have pins for securing containers. Special-purpose platform wagons with axles and bogies have additional equipment for containers, swap bodies, vehicles, or coils. Of the platform wagons, only about one-third are designed to carry containers. These wagons can also be fitted with sliding side walls (similar to special-purpose covered wagons) or tarpaulins to protect the load.

Although platform wagons were commonly used in freight transport, the containerization of transport has strengthened their role in rail transport. Increased investment in intermodal transport has led to an increase in rolling stock in recent years, including the number of platform wagons at the disposal of rail operators and wagons adapted for intermodal transport (Fig. 1) [10].

Table 1

Structure of traction vehicles and wagons of Polish freight operators from 2011-2019 [10]

traction vehicles	Years								
	2011	2012	2013	2014	2015	2016	2017	2018	2019
locomotives	3682	3625	3657	3483	3596	3632	3451	3506	3655
electric	1456	1431	1491	1388	1475	1502	1419	1445	1509
exhaust	2226	2194	2166	2095	2121	2130	2032	2061	2146
wagons									
coal trucks	62444	60530	60234	59270	59641	61919	59432	61677	61477
normal structure E	46320	45501	45365	45111	45446	46752	45173	46990	46757
special structure F	16124	15029	14869	14159	14195	15167	14259	14687	14720
covered wagons	4927	4659	4493	4160	4100	3976	3897	2075	2065
normal structure G	3028	2761	2595	2264	2207	2084	2006	171	148
special structure H	1899	1898	1898	1896	1893	1892	1891	1904	1917
platforms	11588	11144	11190	11668	11603	11541	12551	12973	13453
on the axles									
normal structure K	798	612	608	592	590	578	570	555	602
special structure R	30	30	138	212	14	20	58	100	20
on the bogies									
normal structure L	5649	5391	5258	5214	5261	5029	5125	5362	5768
special structure S	5111	5111	5186	5650	5738	5914	6798	6956	7063
other	22158	22800	22200	11531	15562	14902	15249	14624	14159
with an opening roof T	1197	1282	1220	1226	1256	1273	1289	1596	1555
special U	6339	5747	5980	6147	6124	6291	6347	5393	4348
tank wagons Z	13224	14371	14129	3887	7602	6768	7068	7086	7232
working, social	1398	1400	871	271	580	570	545	549	1024

There were almost 2,000 more platform wagons at the carriers' disposal at the end of 2019 than in 2011. In 2019, 70 new platform wagons adapted for the carriage of containers and 83 wagons for the carriage of military vehicles were introduced into service on the Polish railway network. It should be borne in mind that from the EU's current financial perspective, as part of the implementation of investment projects for intermodal transport, the market will be retrofitted with around 3,400 new platform wagons by 2023, which will affect the average age of platform wagons at the disposal of railway operators but will not change the unfavorable trends in this case. Fig. 2 shows the average age of platform wagons in 2019 and 2018.

The second most numerous group of wagons to be transported are **coal wagons**. They are mainly designed to transport loose materials that are not sensitive to weather conditions, but they can and are also used to transport medium-sized timber, the so-called rollers measuring between 0.5 m and 2.6 m. While the number of aggregate transports has been declining in recent years, the number of these wagons at the disposal of freight operators has remained at a similar level. The decline in the carriage of energy raw materials recorded in 2019 has influenced further decisions on investment plans. Wagons are being used less frequently to transport general cargo, piece cargo, and mail. The number of these wagons has fallen by almost 60% [10].

The third group of wagons that can be used directly for the transport of containers are platform wagons on special construction bogies (type S), the number of which is considerable (4,348 units in 2019) and most of which could also be used for the transport of timber after appropriate modernization.

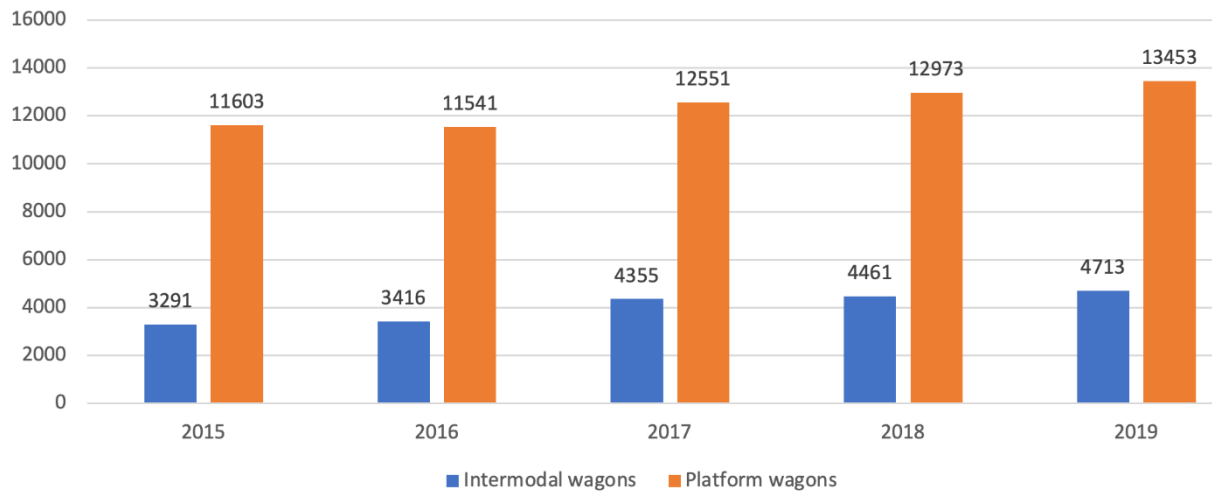

Fig. 1. Number of platform wagons, including those adapted for the carriage of containers, 2015-2019 [10]

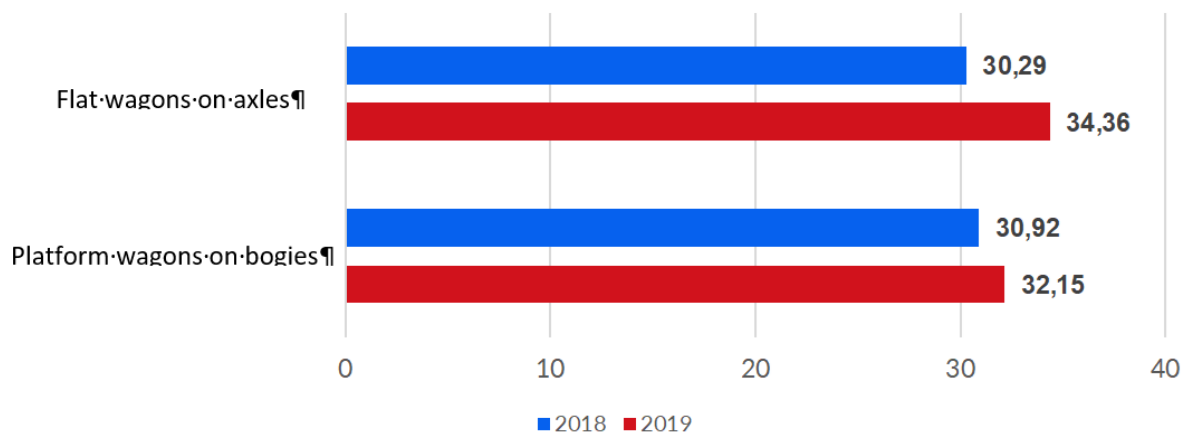

Fig. 2. Average age of freight operators' platform wagons in 2018 and 2019

The above analyses show that the growth rate of intermodal transport in which the container is the basic load unit is not keeping pace with the growth rate of platform wagons adapted to carry containers. However, platform wagons on special-purpose bogies designed to carry containers (e.g., the Sgs series) cannot be used to carry logs, which makes it impossible to use them to reduce the so-called empty mileage and thus improve the economic efficiency of timber transport.

Various measures are therefore being taken to improve this relationship. One possibility is to adapt a platform wagon of the special type for the carriage of containers by placing an interchangeable basket structure on it, which would also make it possible to eliminate empty runs of such wagons, using the platform to carry timber in the basket. This will be considered in the next section.

4. THE STANCHION BASKET PROTOTYPE AS AN INNOVATIVE AND VERSATILE SOLUTION

With the aim of improving the indicators characterizing the profitability of timber transport, among other things, a project proposal was prepared under the Intelligent Development Operational Programme 2014-2020 to develop an innovative timber transport service based on a multipurpose stanchion basket [4]. When embarking on the design of the basket, the following basic assumptions were made:

1. The modular stanchion basket is designed to transport timber, long products (e.g., pipes, rods), as well as containers and palletized products in various configurations.

2. The stanchion basket will be adapted to sit directly on existing wagon platforms equipped with container pins, so no special assembly is required. Examples of rail wagons with which the stanchion basket should work:
 - platform wagon of a type designed to carry containers with a total length of 40 feet,
 - platform wagon of a type designed to carry containers with a total length of 80 feet, and
 - platform wagon of a type designed to carry containers with a total length of 90 feet.
3. In the basic version, the stanchion basket will consist of three modules: a central and two side modules. The side modules will be their mirror image.
4. Cargo can be transported in a variety of configurations:
 - three 3x20' twenty-foot containers,
 - two containers in a 40'+20' or 20'+40' configuration,
 - 20' container + bulk wood at the same time,
 - 40' container + bulk wood at the same time, and
 - two 2x20' containers + bulk wood at the same time.
 Changing the configuration of the containers should be simple, should not require moving the stanchions or the entire basket, and should be possible using typical tools.
5. For reasons related to structural strength, the stanchion basket must comply with the requirements of EN 12663 and the container strength regulations. The geometry of the attachment points of the stanchion basket to the wagon platform is compatible with 20' and 40' container wagons in accordance with ISO-668, ISO-3874, and ISO-1161. The stanchion basket, together with the railway wagon on which the basket is installed, must comply with EN 15273 so that the permissible geometrical dimensions of the railway gauge are not exceeded. The assumed profile of the railway gauge is GB1.

5. SIMULATION ANALYSES OF THE BASKET MODEL

Given the assumptions, the existing container platform wagons in service, and the possibility of the foundation of the basket, the following wagon types were adopted for the analyses: Sgmnns 40', Sgns(s) 60', Sggrs(s) 80', and Sggmrss 90'.

The analysis included the feasibility of obtaining a suitable load length with different basket arrangements and log loads of different lengths. The analysis was carried out on CAD models. For example, Figs. 3 a and b show a Sggmrss wagon with side and center baskets in place.

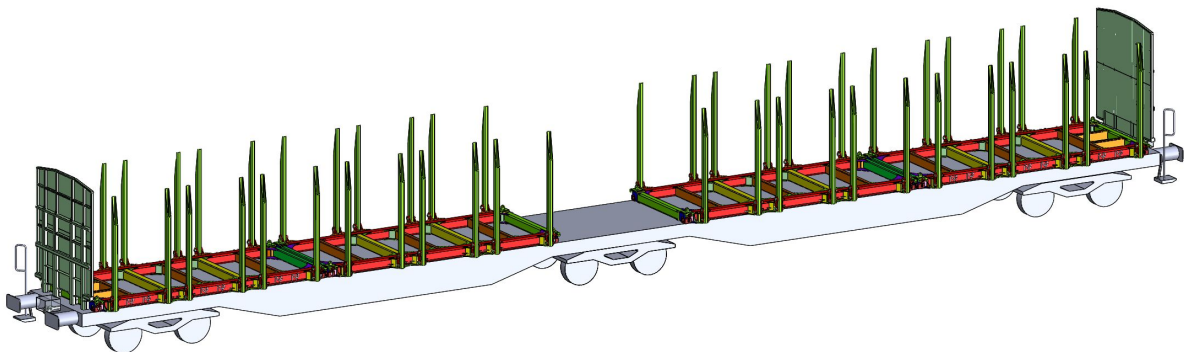

Fig. 3a. Model of a Sggmrss 90' type wagon with baskets

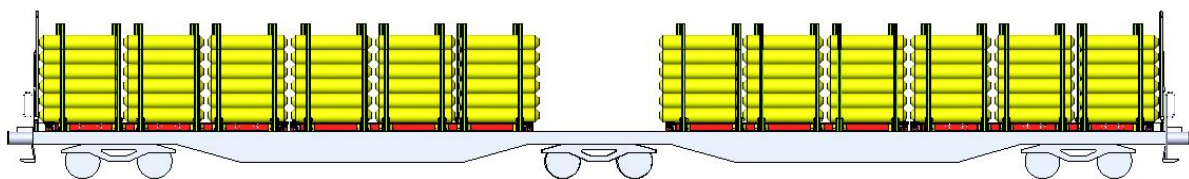

Fig. 3b. Sggmrss type wagon with baskets and a 2-m log load

The design and construction of the prototype basket followed the generally accepted principles for the construction or modernization of rail vehicles or their components [11]. A 3D model of the basket was made using Autodesk Inventor 2019. An example of a basket end module for unfolded and folded stanchions is shown in Figs. 4 a and b.

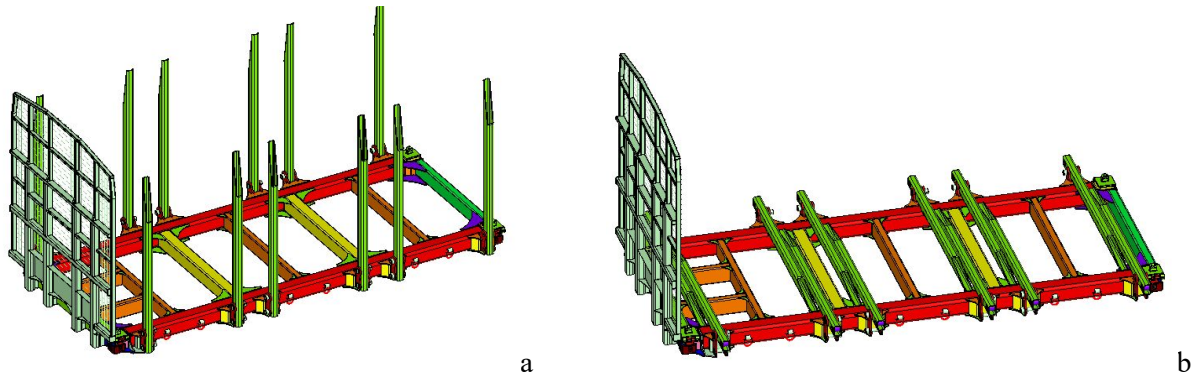

Fig. 4. End basket module: a) stanchions unfolded and b) stanchions folded

A structural design of the stanchion basket was made for the assumptions and verified by strength calculations. The calculations carried out for static and fatigue strength conditions at the characteristic points of the nodes, and the points of attachment of the stanchions to the basket frame and the load support points showed that the stanchion basket designs met the adopted strength criteria for the load cases considered. A linear finite element model was used in the calculations. The calculation procedure followed PN-EN 12663-1+A1:2015-1 and PN-EN 12663-2:2010 “Railway applications - Structural and strength requirements for railway vehicle bodies, part 1 and part 2”.

For the simulation calculations, 11 extraordinary load cases and 10 fatigue load scenarios were defined. For the fatigue analyses, the Huber-von Mises criterion of not exceeding a reduced stress value of 143 MPa and a safety factor of 1.1 (steel S355) were applied.

The computational models were made in Altair HyperMesh 2017, and the calculations were performed in Altair OptiStruct Analysis 2017 environment using the quasi-static calculation algorithm. The analysis and presentation of the computational results were performed in Altair Hyper View 2017. FEM models of the extreme and middle bins were developed assuming a linear-elastic material, and small displacement theory was adopted for the analysis. The structure was modeled using shell elements with an average dimension of 12 mm. An example FEM model of the extreme and middle basket is shown in Figs. 5 a and b.

Simulation analyses of fatigue loading on basket structures and fixings were performed for the cases of container loading and a load of wooden logs.

The load models shown in Fig. 6 were adopted in the case of the analysis of log impacts on the basket stanchions or the end wall and in the case of container loading.

Simulations were carried out for 24 scenarios, taking into account the following cases: end bin, mid-bin, container load, cargo load, and concentrated, distributed constant, or variable forces resulting from the acceleration field. The figures show example simulation results for container loading (Fig. 7) and load loading (Fig. 8).

The results of simulation calculations of stresses and displacements for the case of steady-state loads showed that the resulting stresses did not exceed the allowable stresses for the assumed safety factor of 1.15, $329 \text{ MPa} < R_e = 355 \text{ MPa}$, while in the case of ad hoc loads, for some scenarios and points in the basket model, there was a slight exceeding of this value but not exceeding the yield point of the material, reaching a value of the utilization factor U of 1.07 ($U = \delta_c / \delta_{dop}$). It follows from this that the safety factor is ~ 1.08 , less than 1.15, which is also very small, and we recommend choosing it a bit greater.

For all fatigue load cases, the determined utilization factors U take values less than 1. As for the utilization factor, it is always selected less than 1.

The results were used to assess the effect of the load on the basket structure in a conservative manner, as it is difficult to assess the behavior of the load under actual operating conditions, given the range of

loads generated and their dependence on actual friction coefficients. As the prototype structure will be subjected to experimental tests, these values will be verified in real load conditions.

In terms of the ad hoc and fatigue loads tested, the design of the baskets in the extreme and central configurations meets the requirements of the standards [12, 13].

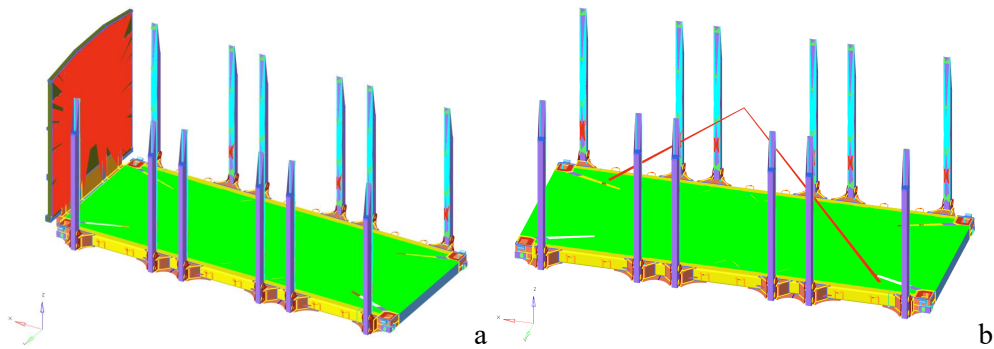

Fig. 5. FEM models of the (a) outermost and (b) central basket

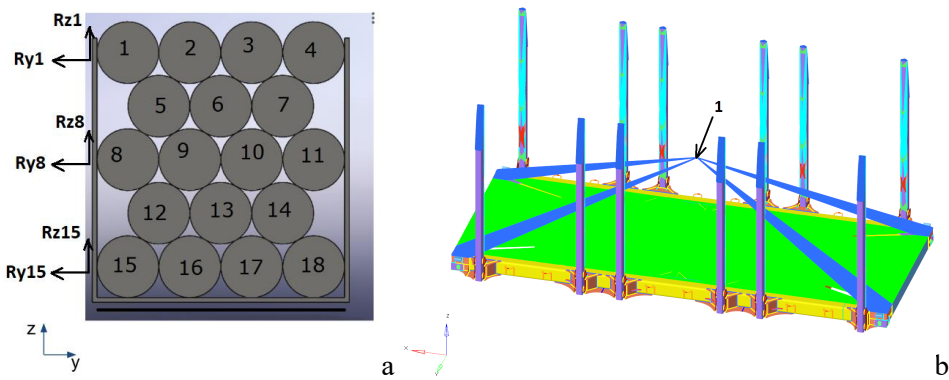

Fig. 6. Bin load models: a) log load and b) container load

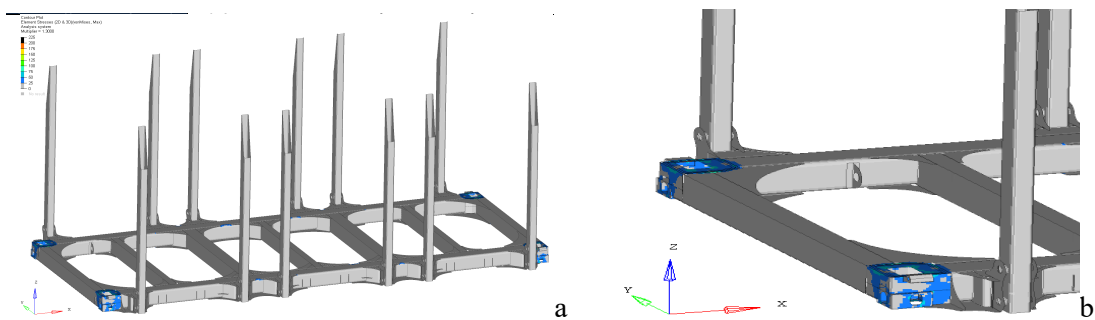

Fig. 7. Result of simulation of container basket loading: a) stresses and b) areas of increased stresses

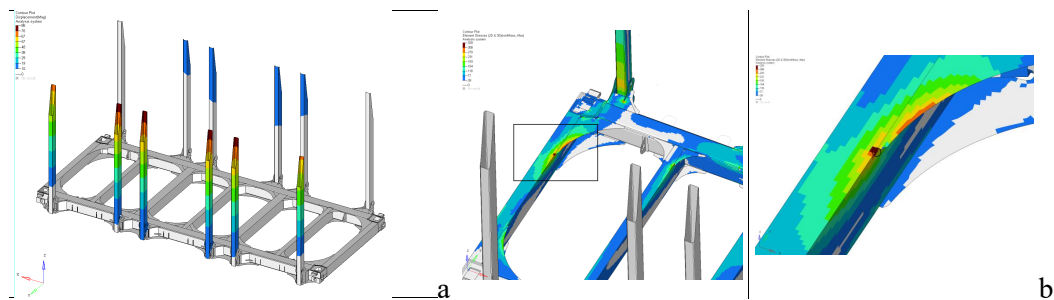

Fig. 8. Simulation result of a loaded basket, (a) displacements under lateral forces, (b) stresses with the indication of local exceedance of critical values

6. TESTING A PROTOTYPE STANCHION BASKET

Tests of the prototype were carried out on the test stands of the Railway Institute, and the results are included in the report [14]. The prototype of the basket was placed on the Rgmms series wagon with the number 31 51 3966, 1, which is operated by PKP CARGO. The tests were performed for a basket loaded with timber and a 40' type container. According to the developed test scenario, the following tests were performed:

1. Measurements of the torsional rigidity of the body C_t^* of a wagon loaded with and without a stanchion basket.

According to UIC leaflet 530-2, the value of body torsional stiffness C_t^* should be in the range of $(0.2 \text{ to } 25.0) \times 10^{10} \text{ [kNmm}^2/\text{rad]}$.

The torsional stiffness of the body of the Rgmms series platform wagon equipped with stanchion baskets determined during the measurements was $C_{t_{wk}}^* = 2.336 \times 10^{10} \text{ [kNmm}^2/\text{rad]}$. In the case without stanchion baskets, it was $C_{t_w}^* = 1.607 \times 10^{10} \text{ [kNmm}^2/\text{rad]}$.

2. Driving safety research on an allocated track.

Tests were carried out according to method no. 1 described in EN 14363 - Section 6.1.5.1 for the passage of a Rgmms series platform wagon through a curve with a radius of 150 m at a speed of less than 10 km/h, recording the elevation of the wheel from Δ_{\max} on 10 measuring sections. The maximum value of lift should not exceed $\Delta_{z\max} \leq \Delta_{z\lim} = 5 \text{ mm}$. An example of wheel lift for one of the runs is shown in Fig. 9.

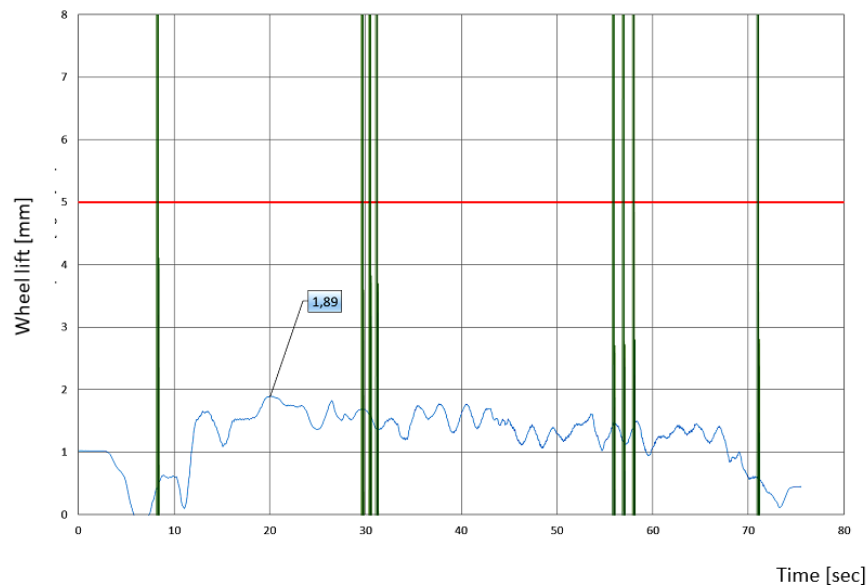

Fig. 9. Lifting of the platform guide wheel during passage 3 through an arc with radius $R = 150 \text{ m}$

During the runs of the test wagon loaded with empty baskets, the recorded wheel lift did not exceed the permissible value of $\Delta_{z\max} = 5 \text{ mm}$.

3. Strength tests of stanchion baskets in empty and loaded conditions during collisions on the Research Run-up Hill.

The BGR test bench enables tests to be carried out on the behavior of railway vehicles in the event of a collision (strength tests on the construction of freight and passenger wagons and their components). Four-axle Eas series standard coal wagons, corresponding to type 1 according to UIC 571-2 [16], were used as the impact wagons (ram) and the shielding wagon. On the tested stanchion basket wagon, a strain

gauge system connected to the measuring system was mounted at selected points of the basket. Fig. 10 shows the stanchion basket on the Rgmms platform with the strain gauges mounted, while Fig. 11 shows an example of a strain-gauge plot during the crash test recorded with a strain gauge stuck on the stanchion basket loaded with wooden logs.



Fig. 10. Wagon and stanchion basket on Rgmms platform: (a) strain gauge installation fitted and (b) a wagon with baskets on the test bed

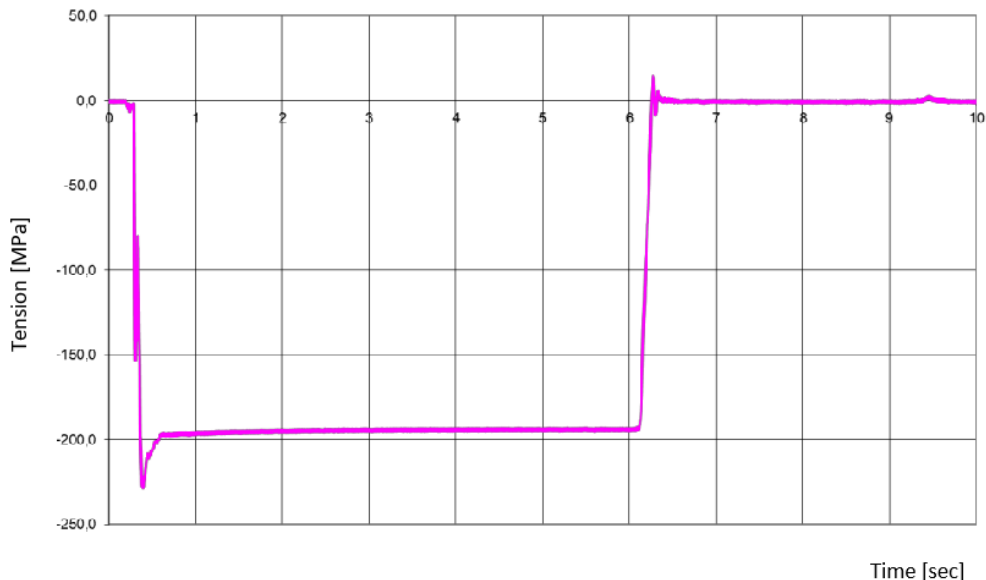

Fig. 11. Strain waveform recorded on the strain gauge. Visible waveform before, during, and after impact

4. Testing the strength of the basket structure. Measurements of stresses from the load.

The tests were static and consisted of recording stresses at selected points in the basket during loading. The basket was loaded with 38.8 t of timber.

Fig. 12 shows the loading of stanchion baskets on a platform wagon.

No cracks or ruptures of structural components occurred on the stanchion baskets after static load tests. There were no visible permanent deformations, and no residual values (deformations) were recorded at the strain gauge points tested. Therefore, the test object complies with the requirements according to clause 5.2.3.1 of EN 12633-2:2010.

5. Static strength testing of stanchions and headwall.

The strength tests of the stanchions consist of applying a torque measuring the forces and stresses at the point of attachment of the stanchion at a designated point in the transverse direction. The same procedure was followed for the end wall as for the stanchion. Fig. 13 shows the test rig used to measure the force and stresses of the stanchion.



Fig. 12. Loading of timber into stanchion baskets on a platform wagon

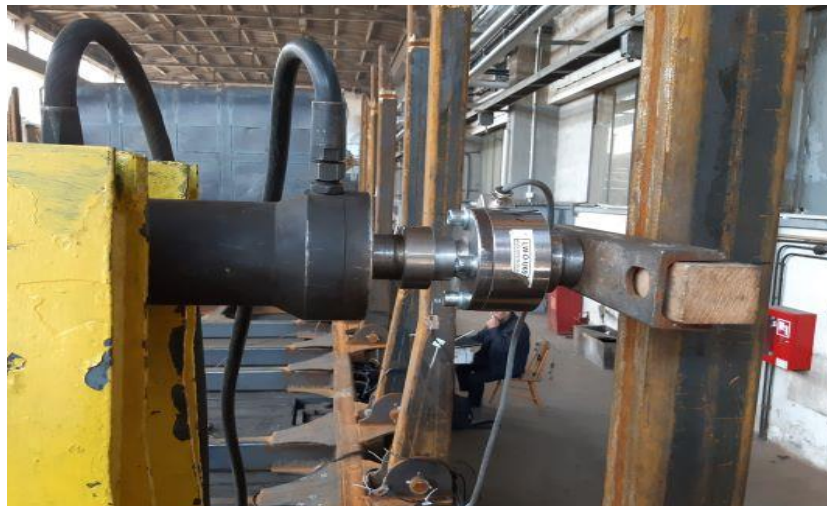

Fig. 13. Standoff force and stress measurement station

During the tests, the allowable stress value was not exceeded for the S460 steel used for the stanchions and the end wall at the selected measuring locations. The recorded residual stresses can be considered negligible.

6. *Investigating the effect of stanchion basket interaction on wagon driving dynamics.*

The study comprised measurements of accelerations at selected points on the body and bogies of a wagon with an unloaded basket on it on the route for a speed of 120 km/h on straight sections. The test methodology and criteria for assessing parameters that determine driving safety were in accordance with the procedure developed based on the requirements of PN-EN 14363. Examples of transverse acceleration waveforms measured on the body with the basket at its two ends are shown in Fig. 14. The blue line is the limiting value of acceleration for the assessment of driving safety.

The results show that the tested stanchion basket wagon tested in the unload condition meets the requirements of the standard in terms of driving safety, dynamic properties of the running system, and track interaction.

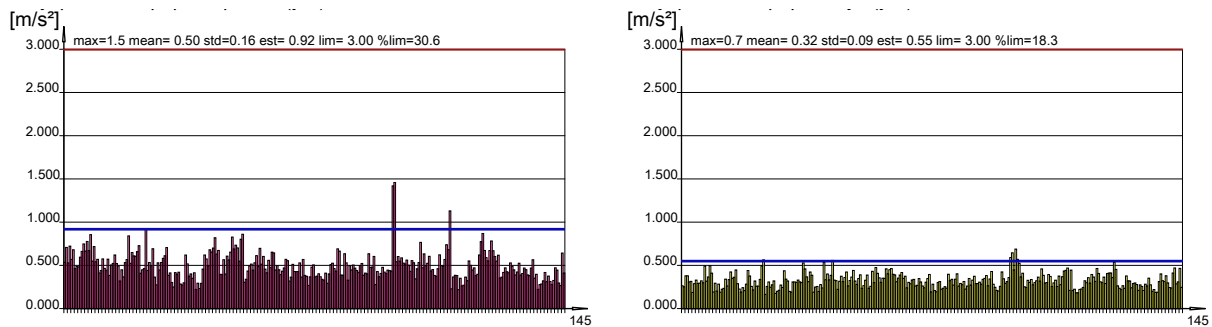

Fig. 14. Transverse acceleration waveforms recorded on the body of a wagon with a basket installed on
a) the front of the wagon and b) the rear of the wagon

7. Testing the attachment of stanchion basket equipment during runs.

The test consisted of assessing the fixing of the container pins with which the stanchion baskets are equipped and which are used to fix the container to the stanchion basket during the run-up (i.e., the overrun of the test wagon with baskets on a free-standing loaded wagon). The tests were carried out on the “Research Run-up Hill” at the Railway Institute in accordance with Instruction Ch-6 of PKP CARGO.

No permanent deformation or damage to the wagon, stanchion basket, or container structure was found after subsequent run-in tests.

8. Analysis of gauge calculations.

Based on the requirements of EN 15273-2, calculations were performed for the gauge of Sggrms (90'), Sggrs (80'), and Rgmms (40') wagons with stanchion baskets. The results indicate that the tested vehicle-stanchion basket systems meet the requirements of the mentioned standard regarding the possibility of passing through the kinematic gauge GB1.

The measurements described above and the analysis of the results obtained were carried out in accordance with the WAG TSI using the methodology given in EN 14363, EN 15839, and EN 15273, as well as the ERRI B12 DT 135 report and UIC 530-2.

The results of the prototype testing allowed the rectification of the errors noted and improvements to the basket design. They also allow the preparation of the documentation necessary to obtain a certificate of release for operation to proceed.

7. CONCLUSIONS

This paper aims to reduce the unfavorable disproportion in freight transport between road and rail by proposing a solution for innovative technology for transporting loads such as timber, pipes, beams, and containers on one type of wagon based on the use of a special structure, called a stanchion basket, mounted on a platform wagon. The developed basket design was used to build a prototype. Both at the design and construction stage and after the construction of the prototype, a number of tests were carried out to verify the assumptions made, bearing in mind the fatigue-strength parameters of the individual elements of the basket, which are decisive for the safety of transport and compliance with the provisions of documents such as DTR and DSU. These tests and the results are included in the article. Particular attention was paid to strength analyses and fatigue assessments of the baskets' construction and, in the case of a basket located on a platform, the fulfillment of requirements related to the maintenance of the gauge. According to the results, the structure of the basket meets the requirements outlined in the standards for railway vehicles.

Tests were also carried out under real operating conditions of the platform wagon system with a prototype basket installed on it. These tests made it possible to improve the design with a view to its operational utility and safety. The results, in the form of a prototype and technical and operational documentation of the basket, were used to prepare an application for a certificate of release for operation.

The authors did not conduct a comparative analysis of theoretical, numerical, or natural experiments due to the limited scope of the study.

Acknowledgments

The project was co-financed by the European Union from the European Regional Development Fund under the Operational Programme Intelligent Development. The project is realized as part of the competition of the National Centre for Research and Development Fast Track.

References

1. *Transport – wyniki działalności w 2021 r.* GUS, Informacje statystyczne. Warszawa, Szczecin. 2022. Available at: https://stat.gov.pl/files/gfx/portalinformacyjny/pl/defaultaktualnosci/5511/9/21 /1/transport_wyniki_dzialalnosci_w_2021_r.pdf. [In Polish: *Transport - business performance in 2021*. CSO, Statistical information. Warsaw, Szczecin].
2. Tomaszewski, T. Nowoczesne konstrukcje wagonów towarowych do przewozów specjalizowanych. *TTS*. 2004. No. 3. P. 12-20. [In Polish: Modern designs of freight wagons for specialised transport].
3. Marciniak, T. & Szkoda, M. Analiza łańcucha dostaw surowca drzewnego. *Autobusy*. 2013. Vol. 14. No. 3. P. 1497 – 1506. [In Polish: Analysis of the wood raw material supply chain. *Buses*].
4. *Projekt NCBiR – WP Radwan Sp. z o.o., 01.01.01-00-0986/19 pn. „Opracowanie innowacyjnej usługi przewozu drewna w oparciu o wielozadaniowy kosz kłonicowy”*. [In Polish: *NCBiR project “Development of an innovative timber transport service based on a multipurpose stanchion basket”*].
5. *Grupy towarowe w transporcie kolejowym*. Urząd Transportu Kolejowego. Warszawa. 2018. [In Polish: *Freight groups in rail transport*. Railway Transport Office. Warsaw].
6. *Rocznik statystyczny GUS*. 2022. [In Polish: *CSO Statistical Yearbook*].
7. *Raport. Lasy Państwowe*. 2018. [In Polish: *Report*. National Forests. 2018].
8. *Przewóz drewna z Czech*. Available at: <https://cdcargo.pl/aktualnosc/przewoz-drewna-z-czech-dopolskich-portow-wagonami-gigawood/>. [In Polish: *Carriage of wood from the Czech Republic*].
9. *Transport intermodalny. Automatyzacja, technologia, infrastruktura i tabor*. Polski Instytut Transportu Drogowego. Warszawa, 2021. [In Polish: *Intermodal transport. Automation, technology, infrastructure and rolling stock*. Polish Institute of Road Transport. Warsaw].
10. *Tabor kolejowy*. 2019. Available at: <https://utk.gov.pl/download/1/61082/Taborkolejowy2019.pdf> [In Polish: *Railway rolling stock*].
11. Chudzikiewicz, A. & Uhl, T. Metodyka modyfikacji konstrukcji na przykładzie pojazdu szynowego. In: *Konferencja Sympozjon PKM 2001*. [In Polish: Methodology of structural modification on the example of a rail vehicle. In: *Conference Symposium PKM 2001*].
12. PN-EN 12663-1+A1:2015-1 *Kolejnictwo. Wymagania konstrukcyjno-wytrzymałościowe dotyczące pudeł kolejowych pojazdów szynowych – Część 1: Lokomotywy i tabor pasażerski (i metoda alternatywna dla wagonów towarowych)*. [In Polish: *Railway applications. Structural and strength requirements for railway vehicle bodies - Part 1: Locomotives and passenger rolling stock (and alternative method for freight wagons)*].
13. DVS 1612:2014-08 *Gestaltung und Dauerfestigkeitsbewertung von Schweißverbindungen an Stählen im Schienenfahrzeugbau*. 2014. [In German: *Design and endurance strength analysis of steel welded joints in rail-vehicle construction*].
14. Sprawozdanie Nr LW/56.08.20 z badań *Opracowanie innowacyjnej usługi przewozu drewna w oparciu o wielozadaniowy kosz kłonicowy*. Instytut Kolejnictwa. Warszawa. 2021. [In Polish: Research Report No. LW/56.08.20 *Development of an innovative timber transport service based on a multipurpose stanchion basket*. Railway Institute. Warsaw].
15. EN 15273-2:2013+A1:2016. *Railway applications - Gauges - Part 2: Rolling stock gauge*.
16. UIC 571-2: 6ED 2001. *Standard Wagons - Ordinary Bogie Wagons – Characteristics*.

17. Eickhoff, B.M. & Evans, J.R. & Minnis, A.J. A review of modelling methods for railway vehicle suspension components. *Vehicle System Dynamics*. 1995. Vol. 24. Nos. 6-7. P. 469-496.
18. Bruni, S. & Vinolas, J. & Berg, M. & Polach, O. & Stichel, S. Modelling of suspension components in a rail vehicle dynamics context. *Vehicle System Dynamics*. 2011. Vol. 49. No. 7. P. 1021-1072.
19. Goodall, R.M. & Ward, C.P. Active control of railway bogies - assessment of control strategies. In: *The International Symposium on Speed-up and Sustainable Technology for Railway and Maglev Systems*. Chiba, Japan. 2015.
20. Mei, T.X. & Shen, S. & Goodall, R.M. & Pearson, J.T. Active steering control for railway bogies based on displacement measurements. In: *Proceedings of 16th IFAC World Congress*. 2005.
21. Abdelaziz, T.H.S. Pole placement for single-input linear system by proportional-derivative state feedback. *Journal of Dynamic Systems Measurement and Control*. 2015. Vol. 137. No. 4. Paper No. 041015. P. 1-10.
22. Xingwen, W. & Maoru, C. & Jing, Z. & Weihua, Z. & Minhao, Z. Analysis of steering performance of differential coupling wheelset. *Journal of Modern Transportation*. 2014. Vol. 22(2). P. 65-75.
23. Polach, O. Characteristic parameters of non-linear wheel/rail contact geometry. In: *Proceedings of 21st IAVSD Symposium*. Stockholm 17-21 August 2009. Paper No. 95.
24. Schiehlen, W. Computational dynamics - theory and applications of multibody systems. *European Journal of Mechanics and Solids*. 2006. Vol. 25. P. 566-594.
25. Kik, W. *MEDYNA. User Manual*. ArgeCare. 1997.
26. Iwnicki, S. (ed.) *Handbook of Railway Vehicle Dynamics*. Taylor & Francis. 2006.
27. Allemang, R.J. & Brown, D.L. A complete review of the complex mode indicator function (CMIF) with applications. In: *Proceedings of International Conference on Noise and Vibration Engineering, ISMA*. Katholieke Universiteit Leuven. 2006.
28. Györgyi, J. Calculation of train dynamic interaction with different model. In: *EURODYN 2005, Structural Dynamics*. Millpress, Rotterdam. 2005. P. 1095-1100.
29. Alvin, K.F. & Robertson, A.N. & Reich, G.W. & Park, K.C. Structural system identification: from reality to models. *Computer and Structures*. 2003. No. 81. P. 1149-1176.
30. Ren, W.X. & Zong, Z.H. Output-only modal parameter identification of civil engineering structures. *Structural Engineering and Mechanics*. Vol. 17. No. 3. P. 429-444.
31. Lowe, O. *Freight Rail Usage and Performance*. Office of Rail and Road. 2023.

Received 19.04.2022; accepted in revised form 28.11.2023