

Transport Problems

Volume 10 Issue 4



Problemy Transportu



GLIWICE 2015

SCIENTIFIC
JOURNAL

TRANSPORT PROBLEMS

Volume 10 Issue 4

PROBLEMY TRANSPORTU

Tom 10 Zeszyt 4

QUARTERLY

WYDAWNICTWO POLITECHNIKI ŚLĄSKIEJ
GLIWICE 2015

CONTENTS

	Page
1. Drożdziel P., Buková B., Brumerčíková E.: Prospects of international freight transport in the East-West direction.....	5
2. Sumaedi S., Yarmen M.: The effect of moral norm on public transport passengers' behavioral intention (case study – public transport passengers in Bogor, Indonesia).....	15
3. Beškovnik B.: Introducing electronic Maritime Single Window by port communities in the Adriatic region	25
4. Madleňák R., Štefunko J.: The optimization approach of postal transportation network based on uncapacitated fixed charge location model in conditions of Slovak Republic	35
5. Lebedevas S., Lebedeva G., Dailydka S., Vaičiūnas G.: Research of impact of the loading on endurance of the freight locomotive engines	45
6. Klementsčitz R., Roider O.: Active measures as part of dialogue marketing promoting the use of public transport in rural areas	57
7. Comi A., Nuzzolo A.: Modelling challenges to forecast urban goods demand for rail	75
8. Ivanov R., Georgiev K., Kadikyanov G., Staneva G.: An experimental research on the wear of truck tire.....	91
9. Boiko M., Lebedinsky K.: Biodegradable lubricant for railway transport.....	99
10. Mašek J., Kendra M., Čamaj J., Milinković S., Vesković S.: Proposal and application of methodology of revitalisation of regional railway track in Slovakia and Serbia. Part 2: State of regional transport in Slovakia and Serbia	107
11. Filipczyk J., Makarova I., Belyaev E.: Analysis of periodical technical inspection systems in automotive transport. The experiences of Poland and Russia	121
12. Kroupnik L., Abdykalykova R., Sładkowski A., Shaposhnik Yu., Shaposhnik S.: Gravity pipeline transport for hardening filling mixtures.....	129
13. Jezierska-Krupa K., Krysiak M., Skarka W.: Advanced driver safety support systems for the urban type vehicle	137
14. Reece D.C., Marinov M.: Modelling the implementation of a baggage transport system in Newcastle upon Tyne for passengers using mixed-mode travel	149
List of reviewers	157

gravity pipeline transport; hardening mixture; coefficient of state

Leonid KROUPNIK*, Roza ABDYKALYKOVA

Kazakh National Research Technical University named after K.I. Satpayev
Satpayev 22, 050013, Almaty, Kazakhstan

Aleksander ŚLADKOWSKI

Silesian University of Technology, Faculty of Transport
Krański 8, 40-019 Katowice, Poland

Yuryi SHAPOSHNIK

Institute of Mining named after N.A. Cninakal, Siberian Branch of Russian Academy of Sciences
Krasnyj prospekt, 54, 630091, Novosibirsk, Russia

Sergeyi SHAPOSHNIK

D.Serikbaev East-Kazakhstan State Technical University
Serikbaev st. 19, 070043, Ust-Kamenogorsk, Kazakhstan

*Corresponding author. E-mail: leonkr38@mail.ru

GRAVITY PIPELINE TRANSPORT FOR HARDENING FILLING MIXTURES

Summary. In underground mining of solid minerals becoming increasingly common development system with stowing hardening mixtures. In this case the natural ore array after it is replaced by an artificial excavation of solidified filling mixture consisting of binder, aggregates and water. Such a mixture is prepared on the surface on special stowing complexes and transported underground at special stowing pipelines. However, it is transported to the horizons of a few kilometers, which requires a sustainable mode of motion of such a mixture in the pipeline. Hardening stowing mixture changes its rheological characteristics over time, which complicates the calculation of the parameters of pipeline transportation. The article suggests a method of determining the initial parameters of such mixtures: the status coefficient, indicator of transportability, coefficient of hydrodynamic resistance to motion of the mixture. These indicators characterize the mixture in terms of the possibility to transport it through pipes. On the basis of these indicators is proposed methodology for calculating the parameters of pipeline transport hardening filling mixtures in drift mode when traffic on the horizontal part of the mixture under pressure column of the mixture in the vertical part of the backfill of the pipeline. This technique allows stable operation is guaranteed to provide pipeline transportation.

САМОТЕЧНЫЙ ТРУБОПРОВОДНЫЙ ТРАНСПОРТ ТВЕРДЕЮЩИХ ЗАКЛАДОЧНЫХ СМЕСЕЙ

Аннотация. При подземной разработке твердых полезных ископаемых все большее распространение приобретают системы разработки с закладкой выработанного пространства твердеющими смесями. В этом случае естественный рудный массив после его выемки замещается искусственным из затвердевшей закладочной смеси, состоящей из вяжущего, заполнителя и воды. Такая смесь готовится на поверхности на специальных закладочных комплексах и транспортируется под землю по специальным закладочным трубопроводам. При этом она транспортируется по го-

ризонтам на несколько километров, что требует обеспечения устойчивого режима движения такой смеси по трубопроводу. Твердеющая закладочная смесь изменяет свои реологические характеристики во времени, что усложняет расчет параметров трубопроводного транспорта. В статье предлагается методика определения исходных параметров таких смесей: коэффициента состояния, показателя транспортабельности, коэффициента гидродинамического сопротивления движению смеси. Эти показатели характеризуют смесь с точки зрения возможности транспортировать ее по трубам. На базе этих показателей предлагается методика расчета параметров трубопроводного транспорта твердеющих закладочных смесей в режиме самотека, когда движение смеси по горизонтальной части под действием давления столба смеси в вертикальной части закладочного трубопровода. Данная методика позволяет гарантированно обеспечивать устойчивый режим трубопроводного транспорта.

1. INTRODUCTION

One of the main in underground mining of solid minerals resources in most countries of the world are developing systems with stowing hardening mixtures. Stowing allows solving a number of different tasks in nature, providing favorable and safe conditions of mining:

- management of rock pressure in production areas, which allows the use of highly efficient development, reduce the loss of minerals in the bowels, improve the safety of mining operations;
- the elimination of voids formed during excavation useful.

Fossil, which gives the opportunity to develop flammable deposits, conduct joint surface and underground development, and conduct selective mining of minerals by grades. The volume of voids formed after mineral extraction enough recess. So, when removing 1 million tons. Ore produced 300 ... 350 thousand m³ of voids. To fill these voids using hardening filling mixture containing binder (usually cement), water and inert filler. Such a volume filling mixes most effectively delivered in stowing with the surface of the earth, where they are prepared, pipeline transport.

Hardening filling mixture characterized by a number of features that affect the mode of movement through the pipeline. Backfill mixture must have a certain fluidity (mobility) and does not delaminate during transport. It must have a certain coherence with the fact that after laying in stowing excess water not stand productive particle binder. In addition it should be borne in mind that the hardening stowing the mixture immediately after preparation tends to structure formation, which significantly changes its rheological characteristics: yield stress, the structural viscosity and resistance to motion. Stable regime of pipeline transport of such mixtures is necessary to ensure that in the technology of filling works, it is a complex task requiring a decision.

2. CHARACTERAZATION OF THE FILLING, HARDENING MIXTURE TRANSPORTABILITY

One of the main operations in technology filling operations is the transportation hardening filling mixture through a pipeline, Currently, most grafting is gravity flow conveying the mixture under pressure to put upright post on Fig. 1.

In pipeline transportation hardening filling mixture is essential to sustainable modes of traffic flow of the mixture without her bundle. This ensures a certain speed mixture and preserving its basic rheological characteristics.

Super plastic mixture and follow the law, Shvedov-Bingham are the most the transportable and have minimal resistance to movement. Hard mixture which is a manifestation of elements "dry friction" in a structural displacement along the pipeline are not suitable, since it can form a blockage. Therefore, from the viewpoint of portability hardening filling mixture is first necessary to assess its

performance, is uniquely determined by the "Liquid" or "Solid" as possible to carry transportable mixture. This indicator is the ratio of state of the mixture KCM. The essence of it in the next.

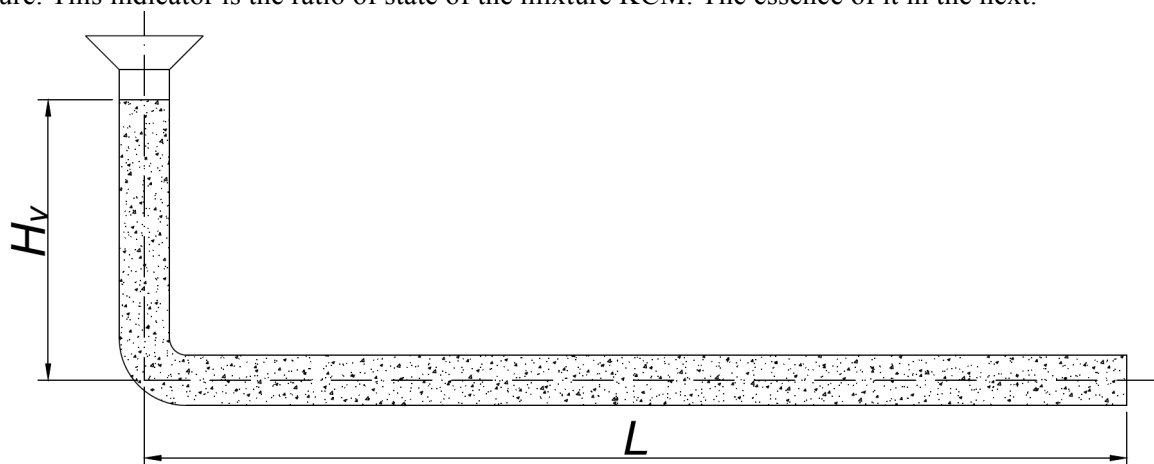

Fig. 1. The calculation scheme of gravity transport for filling, hardening mixture

Рис. 1. Расчетная схема самотечного транспорта твердеющей закладочной смеси

We know from hydraulics, that hydrostatical pressure in any points of the liquid affect extensively equally, that is mean

$$P_x = P_y = P_z.$$

For loose bodies and solids what make lateral pressure that distinguish from force, appendices along an axis. In these bases we can characterize condition of the hardening stowage mix at the moment time relation with P_c pressure on the side of the conduit to pressure of cross-section P_v . This relation will be factor of coefficient K_c mixture.

$$K_c = \frac{P_c}{P_v} \leq 1. \quad (1)$$

For plastic mixtures, obeying to the law Shvedov-Bingham $K_c=1$. When $K_c < 1$ mixture not transportable by pipeline.

Determination of the coefficient K_c is made on a special stand (Fig. 2).

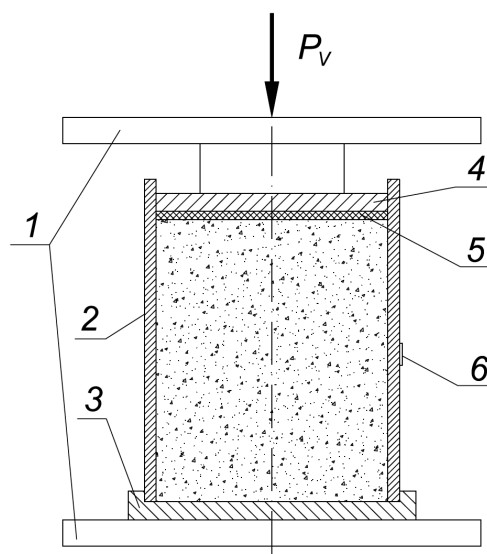

Fig. 2. Scheme of the stand for the determination for coefficient of state: 1 - press plates; 2 - cylinder; 3 - bottom; 4 - piston; 5 - cuff; 6 - strain gauge

Рис. 2. Схема стенда для определения коэффициента состояния: 1 - плиты прессы; 2 - цилиндр; 3 - дно; 4 - поршень; 5 - манжета; 6 - тензометрический датчик

The stand consists from a cylinder with a piston, sealed cuff. On the lateral surface of the cylinder are glued strain gauges recording the value of lateral pressure. In the cylinder load under testing mixture, after that it placed under the press and mixture is compressed. Compression force record with monometer, and lateral force – with galvanometer with resistance bridge. Before starting works stand span on clean water and construction spanning characteristic, with helping that in process testing defining coefficient states mixture.

To calculate of possible range transporting mixture and maximum allowable time of the transporting necessary to know the specific resistance to movement mixture by pipeline depending from its specific physical internals and ages. Resistivity resistance to the movement of mixture can be expressed in absolute or relative terms. This procedure is recommended to use with relative resistivity, which is called "index transportability mixture" and equal to the sinus of the true corner displacement under the action by its own mixture weight of given consist in diameter of pipe. This indicator a is associate with critical shear stress τ_0 with relation

$$a = \frac{m_f \cdot \rho_t}{\pi d_p} \tau_0 = \frac{4\tau_0}{\rho_t d_p}, \quad (2)$$

where; d_p – diameter of the transporting pipeline, m; m_f – specific weight of mixture in pipe, kg/m;

ρ_f – hardness of stowing mixture, kg/m³; τ_0 – mixture critical shear stress.

Determination of transportability for mixtures of different compositions perform on a special stand, shown schematically in Fig. 3. It is a tube, that between two light tight washers placed portion of new weighted and stowing mixture.

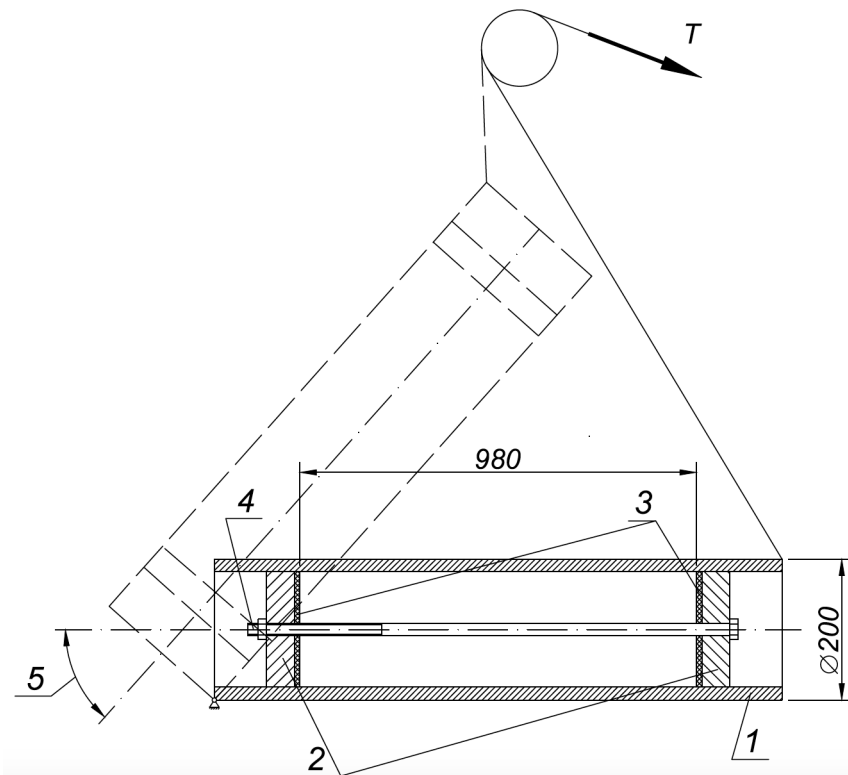

Fig. 3. Scheme of the stand for definition of transportability indicator: 1 – tube; 2 – washer; 3 – compactor; 4 – tie rod; 5 – corner of starting move mixture φ

Рис. 3. Схема стенда определения показателя транспортабельности: 1 – труба; 2 – шайбы; 3 – уплотнители; 4 – стяжной стержень; 5 – угол начала движения смеси φ

During slow lifting one end of the pipe determine by the angle of displacement of the mixture at the beginning of the pipe φ . Then

$$\alpha = \frac{(m_f + m_s) \cdot \sin \varphi - (m_s \cdot \sin \varphi + m_g)}{m_f}, \quad (3)$$

where: m_f - weight of the testing portion sowing mixture, kg; m_s - weight of the washer with rod, kg; m_g - weight of the additional load, necessary for moving piston, kg; (when $\varphi < 90^\circ$, $m_g = 0$); φ - angle of the starting move washers with rod, without mixture, degree.

Depending (3) is obtained from the equation from the limit equilibrium of the "piston-mix".

Due with that transportability changes eventually, in the calculations is recommended to use an average of:

$$\alpha_m = \alpha_0 + \frac{K_1 t}{2}, \quad (4)$$

where: α_m - index of the new transportable mixture; K_1 - coefficient of the aging mixture, 1/min; t - time of transporting mixture by pipeline, min.

For tube with diameter, what different from testing stand tube, index of transportability can be determine by this formula

$$\alpha_{o1} = \frac{\alpha_o d}{d_1}, \quad (5)$$

where: α_o and d - respectively index of transportability and diameter of the stand; α_{o1} and d_1 - too, actual stowing pipeline.

How showed testing, index of transportability α significantly depend on consumption binder value, transport pipeline diameter, size distribution of the aggregate and water specific consumption (Fig. 4).

Second index, which characterize stowing mixture motion mode - its resistance to the mixture motion hydrodynamic coefficient.

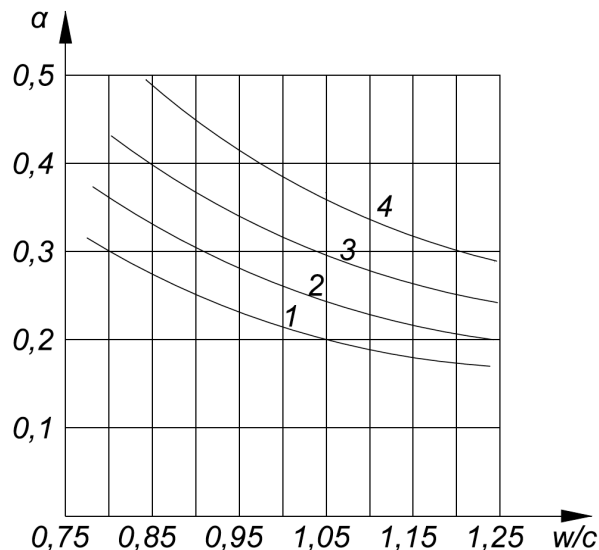

Fig. 4. Changing of stowing, hardening mixture transportability index: 1. cement consumption 300 kg/m³; 2. cement consumption 200 kg/m³; 3. cement consumption 250 kg/m³; 4. cement consumption 150 kg/m³

Рис. 4. Изменение показателя транспортабельности твердеющих закладочных смесей

How showed structural motion adherently-plastic mixtures most answered Shvedov-Benham law.

$$\tau = \tau_o + \mu \frac{dv}{dr}, \quad (6)$$

where: τ - shear stress in the stowing mixture; τ_0 - max stress of the stowing, hardening mixture

(shear stress in the mixture at the start of its flow); μ - structural viscosity of mixture; $\frac{dv}{dr}$ -

speed gradient; v - speed of the mixture in the present point, m/s; r - range from pipeline axis to the present point, m;

Practical using this depending – difficult, because we don't have reliable methods of definition μ and we don't have real value of layer n , which depend on mixture viscosity and its speed of motion. In the calculation we can use with another indexes – coefficient resistance for mixture hydrodynamic motion K_h

$$K_h = 1 + K_2 v^n, \quad (7)$$

where: K_2 and n – coefficients experimentally determined and depending on the composition of filling mixture.

Generally, during the changing of the state of the mixture coefficient K_c from 0 to 1, K_2 can vary from 0 to 2. The exponent n for the viscous-plastic mixtures depends on the velocity of the mixture, its kinematic viscosity and pipe diameter, that affect the value of the boundary layer.

Dependence for coefficient calculation K_2 was obtained according to the results of experimental investigations on the existing stowing installation.

$$K_2 = \frac{\Delta P - \alpha_m \rho_f \ell_k}{\alpha_m \rho_f \ell_k v^n}, \quad (8)$$

where: ΔP - loss of pressure of the mixture in the control plot, Pa; ℓ_k - the length of the test area, m;

α_m - the average value of the transportability index on the control area.

These characteristics enough to accounting regime of mixture.

3. PARAMETER DEFINITION OF THE HARDENING FILLING MIXTURE FLOWING TRANSPORT

The equation of dynamic mixture equilibrium in stowing pipe, that have a vertical and a horizontal sections (Fig. 1) may be represented as

$$\rho_f g S H_V - \rho_f g S H_V (1 + \gamma) \alpha_m + (1 + K_2 v^n) - \rho_f S H_V (1 + \gamma) \cdot \frac{dv}{dt} = 0, \quad (9)$$

where: S – area of transversal pipeline section, m²; $\gamma = \frac{L}{H_V}$ - relative length of the transport, stowing mixture.

Accepting $n = 2$ and performing the transformation we obtain

$$\frac{dv}{dt} + b^2 v^2 = f^2, \quad (10)$$

where

$$f = \sqrt{\frac{g[1 - \alpha_m(1 + \gamma)]}{1 + \gamma}}, \quad (11)$$

$$b = \sqrt{g K_2 \alpha_m}. \quad (12)$$

Solving the equation (10), relatively t we own

$$t = \int \frac{dv}{f^2 - b^2 v^2} + C = \frac{1}{2bf} n \left| \frac{f + \alpha v}{f - \alpha v} \right| + C. \quad (13)$$

When $t=0$, $v=0$, therefore $C=0$ too.

Solving the equation (13), relatively v must be equal

$$v = \frac{f(e^{2bft} - 1)}{b(e^{2bft} - 1)}. \quad (14)$$

Testing of equation (14) show, that acceleration process continuing of the hardening, filling mixtures in transport pipeline at different possible values m , α_m and K_2 varies anywhere from 5 to 20 s.

Neglecting acceleration continuing and take $(e^{2bft} - 1) \approx (e^{2bft} + 1)$ we get moving speed rational meaning of hardening, filling mixture by pipeline.

$$v = \sqrt{\frac{1 - \alpha_m(1 + \gamma)}{K_2 Q_m(1 + \gamma)}}, \text{ m/s.} \quad (15)$$

Making process of filling mixture unstable. Then possible productivity fluctuations of filling facility then, how consequence, irregularity giving mixture to transport pipeline. To correct this we must inter to formula (15) safety coefficient $K_\beta = 1,25 \dots 1,5$. Minimum meaning of K_β complies fully to filling automated complex, maximal – to the complex with partial automating.

Taking into account safety coefficient formula (15) change to

$$v = \sqrt{\frac{1 - K_\beta \alpha_m(1 + \gamma)}{K_\beta K_2 Q_m(1 + \gamma)}}, \text{ m/s.} \quad (16)$$

Solving equation (16) relatively β we obtain hardening, filling mixture transportation of maximal and relative range for specific conditions.

$$\gamma = \frac{2 - K_\beta(2a_o + K_1 t)(1 + K_2 v^2)}{K_\beta(2a_o + K_1 t)(1 + K_2 v^2)}. \quad (17)$$

Solving equation (17) relatively t we obtain transportation permissible time of hardening, filling mixture without its characteristic substantial loss, what provide moving by pipeline.

$$t = \frac{2 \left[1 - K_\beta a_o(1 + K_2 v^2)(1 + \gamma) \right]}{K_\beta K_1 a_o(1 + K_2 v^2)(1 + \gamma)}, \text{ s.} \quad (18)$$

Equation (17) and (18) determine borders of steady work hardening, filling mixture pipeline transport and critical time of its transportation for gravity plot.

By this methodic calculated transport system for Kazakhstan filling mine complexes.

4. CONCLUSION

The above method allows to precisely defining the main characteristics of hardening filling mixtures, providing a stable mode of transport through pipes. The calculated formulas allow calculating the real conditions for the main parameters of the transport system in the design and operation of filling complexes mining enterprises.

References

1. Битимбаев, М.Ж. & Крупник, Л.А. & Шапошник Ю.Н. *Теория и практика закладочных работ при разработке месторождений полезных ископаемых*. Алматы: Изд. Ассоциации ВУЗов РК. 2012. [In Russian: Bitimbaev, M.G. & Kroupnik, L.A. & Shaposhnik, Y.N. *Theory and practice of filling works in development of mineral deposits*. Almaty: Publishing House of Kazakh Universities Association].

2. Джваршейшвили, А.Г. *Системы трубопроводного транспорта горно-обогатительных предприятий*. Москва: Недра. 1981. [In Russian: Dzhvarshejshvili, A.G. *Pipeline transport system in mining and processing enterprises*. Moscow: Nedra].
3. Покровская, В.Н. *Трубопроводный транспорт в горной промышленности*. Москва: Недра. 1985. [In Russian: Pokrovskaya, V.N. *Pipeline transport in mining industry*. Moscow: Nedra].
4. Смолдырев, А.Е. *Трубопроводный транспорт*. Москва: Недра. 1980. [In Russian: Smoldirev, A.E. *Pipeline transport*. Moscow: Nedra].
5. Cabrera, V.R. Slurry Pipelines; Theory, Design and Equipment. *J. of World Mining*. 1979. No. 1. P. 56-65.
6. Baker, P.J. & Jacobs, B.E.A. & Bonnington, S.T. *A guide to slurry pipeline systems*. Cranfield: BHRA Fluid Engineering. 1979.
7. Мирзаджанзаде, А.Х. & Мирзоян, А.А. & Гевинян, Г.М. & Сеид-рза, М.К. *Гидравлика глинистых и цементных растворов*. Москва: Недра, 1966 [In Russian: Mirzandganzade, A.H. & Mirozoyan, A.A. & Gewinyan, G.M. & Seid-rza, M.K. *Hydraulic of clay and cement mortars*. Moscow: Nedra].
8. Цыгалов, М.Н. *Подземная разработка с высокой полнотой извлечения руд*. Москва: Недра. 1985 [In Russian: Tsygalov, M.N. *Underground mining with high completeness extraction ores*. Moscow: Nedra].
9. Kroupnik, L.A. & Shaposhnik, S.N. & Yu.N. & Shaposhnik, S.N. & Tursunbaeva A.K. Backfilling Technology in Kazakhstan Mines. *Journal of Mining Science*. 2013. Vol. 49. No. 1. P. 17-21.

Received 21.08.2014; accepted in revised form 29.11.2015